



WxC24 Power Controllers Application Note



November 2007

Contents

1	INTRODUCTION	3
2	MODELS	3
2.1	WAC24 Power Controller	3
2.2	WDC24 Power Controller	4
2.3	WxC24 Power Controller Comparison.....	4
2.4	WxC24 Power Controller Ratings.....	4
3	APPLICATIONS	5
3.1	WAC24 Powered Access Point with Backbone Link/s	5
3.2	WDC24 Powered 2.4 GHz Access Point with 5.8 GHz Backbone Link.....	6
4	POWER CONTROLLER MANAGEMENT	7
4.1	Power Controller Configuration	7
4.2	Power Controller Administration	9
4.3	Power Controller Monitoring	10
4.4	Monitor vs. Admin Privilege Summary.....	10
5	SOFTWARE UPGRADES	11
6	WxC24 POWER CONTROLLER SPECIFICATIONS.....	11
7	MORE INFORMATION.....	12

List of Figures

Figure 1:	WAC24 Power Controller Block Diagram.....	3
Figure 2:	WDC24 Power Controller Block Diagram.....	4
Figure 3:	WAC24 Powered Access Point with Backbone Link/s.....	5
Figure 4:	WDC24 Powered 2.4 GHz Access Point with 5.8 GHz Backbone Link	6
Figure 5:	WDC24 Powered 2.4 GHz Access Point with 5.8 GHz Backbone Link no Switch	6
Figure 6:	Power Controller Configuration UI	7
Figure 7:	Power Controller Administration UI	9
Figure 8:	Power Controller Monitoring UI	10

List of Tables

Table 1:	Admin vs. Monitor Privilege Summary	10
Table 2:	WxC24 Power Controller Specifications.....	11

WxC24 Power Controllers Application Note

1 INTRODUCTION

The WxC24 series of power controllers were designed for Wireless Internet Service Provider (WISP) applications to provide power, monitoring and management of Access Point and Repeater Sites.

Optimized for operation with equipment operating from 18 to 24 VDC they are capable of supplying up to 60W. This Application Note explains their use with Tranzeo wireless equipment; however the principles detailed can be applied to any equipment operating with a DC power input in the range of 18 to 24 VDC.

2 MODELS

There are two models in the WxC24 power controller series – the WAC24 and the WDC24. Both models have the same functional capabilities, the difference between the two (2) units is the power input and power output capabilities of the units.

2.1 WAC24 Power Controller

The WAC24 has an AC power input of 100 to 240 VAC, 47 to 63 Hz and provides dual controlled 24 VDC outputs with a maximum rated load of 60W.

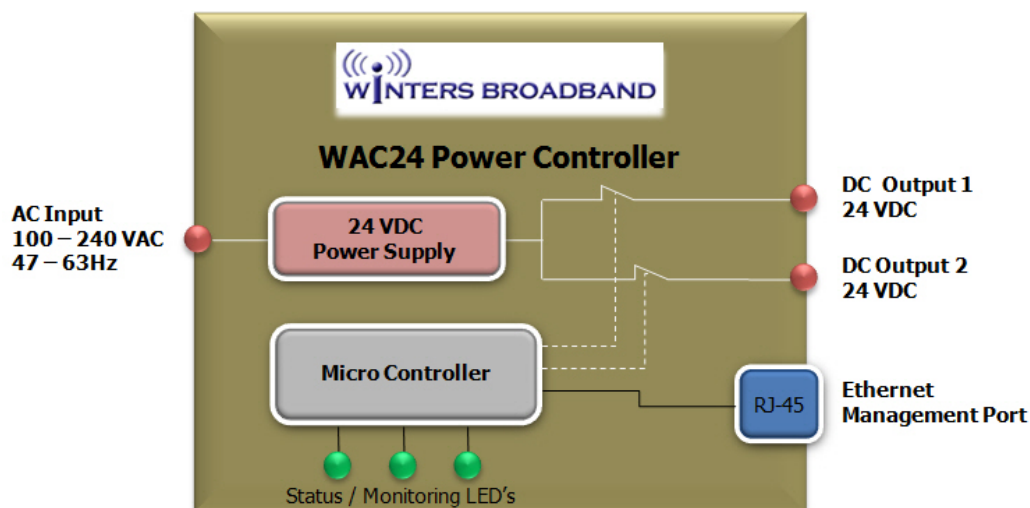

Figure 1: WAC24 Power Controller Block Diagram

2.2 WDC24 Power Controller

The WDC24 has a DC power input of 18 to 24 VDC and provides dual controlled DC outputs at the same voltage as the input, with a maximum load of 60W. The power supply providing the DC input must have sufficient capacity to power the devices attached to the WDC24. This allows the WDC24 to be used with existing Tranzeo 18 VDC or 24 VDC power adapters.

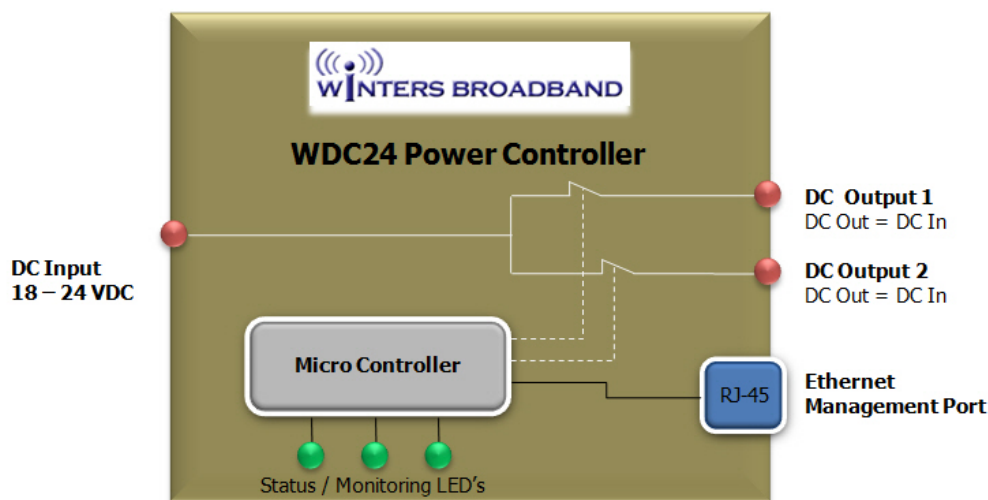

Figure 2: WDC24 Power Controller Block Diagram

2.3 WxC24 Power Controller Comparison

The difference between the models is that the WAC24 has an internal 24 VDC 60W power supply, whereas the WDC24 operates from an external 18 to 24 VDC power supply – the input DC voltage is the same as the output DC voltage in the WDC24.

2.4 WxC24 Power Controller Ratings

The WxC24 Power Controllers are rated to provide 24V of DC output power at 60W and are protected to prevent this rating from being exceeded. If a load of greater than 60W is attached the WxC24 will shut down until the load is reduced to 60W or less.

Each WxC24 DC output is capable of powering up to 36W (1.5A at 24V), the DC output being protected by a solid state fuse should the output capability be exceeded. The DC output is automatically restored once the excess load is removed.

The typical power consumption of a Tranzeo wireless unit is 6W which allows each DC output to power up to six (6) wireless units. If one DC output has a 36W load the second DC output can only deliver a maximum of 24W, which is power to four (4) Tranzeo wireless units.

3 APPLICATIONS

The following applications show the use on WxC24 Power Controllers with Tranzeo wireless equipment.

3.1 WAC24 Powered Access Point with Backbone Link/s

The following configuration could be used at a network center where there is a 2.4 GHz Access Point (Tranzeo TR-6x00) connected to the Internet via an Ethernet switch. There are also one or more 5.8 GHz backbone links (Tranzeo TR-5a) which are being used to connect to other sites in the network.

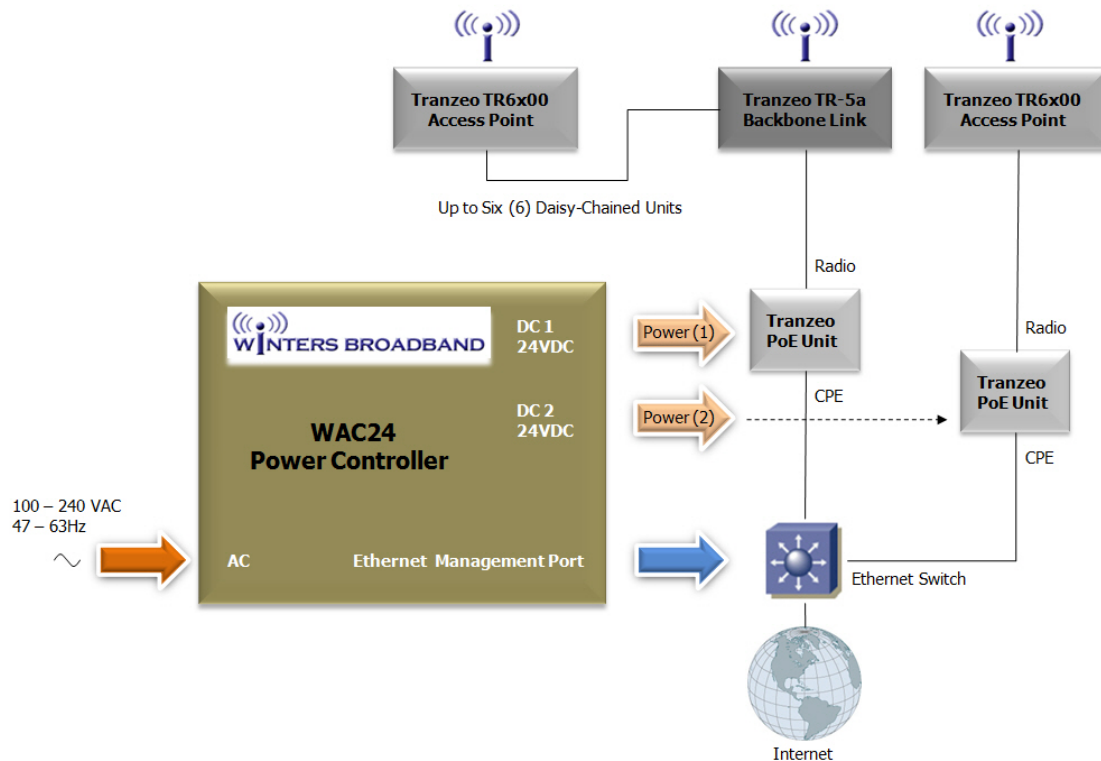

Figure 3: WAC24 Powered Access Point with Backbone Link/s

The dual DC outputs allow the Access Point and Backbone Link/s to be powered and controlled separately. The Access Point PoE (Power over Ethernet) unit is powered from the WAC24 DC output #2, while the PoE unit for the Backbone Links is powered from the WAC24 DC output #1.

Section 4 of this Application Note provides details on the monitoring, reporting and control functions available to simplify the operation and management of networks requiring 24 x 7 x 365 operation.

WxC24 Power Controllers Application Note

3.2 WDC24 Powered 2.4 GHz Access Point with 5.8 GHz Backbone Link

In following configuration, which could be a remote Access Point site, there is a 2.4 GHz Access Point (Tranzeo TR-6x00) connected to the central site by a 5.8 GHz backbone link (Tranzeo TR-5a).

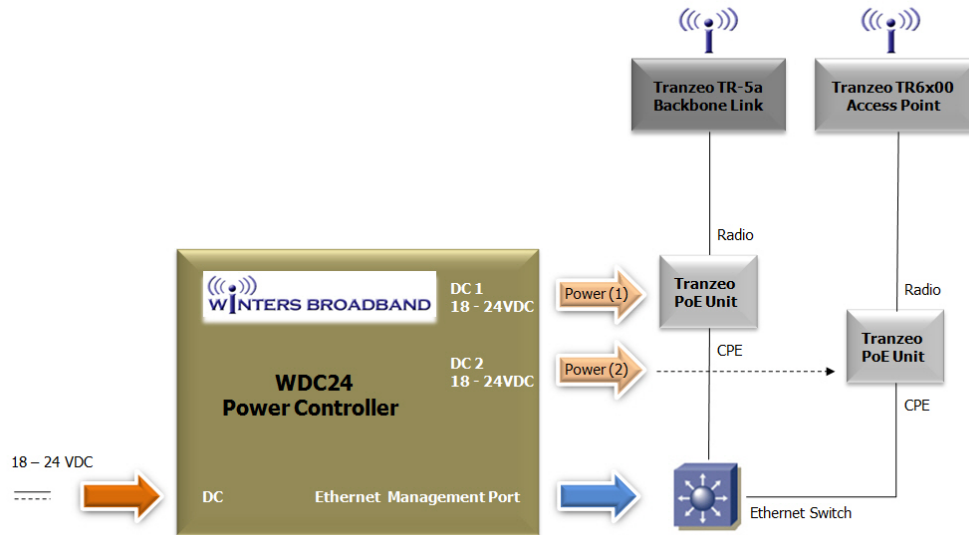

Figure 4: WDC24 Powered 2.4 GHz Access Point with 5.8 GHz Backbone Link

The site utilizes an existing 18 to 24 VDC power supply, such as those supplied with the wireless units. Since the operation of the Access Point is dependent on the operation of the Backbone Link the configuration can be simplified by removing the Ethernet switch and using a single DC output from the WDC24.

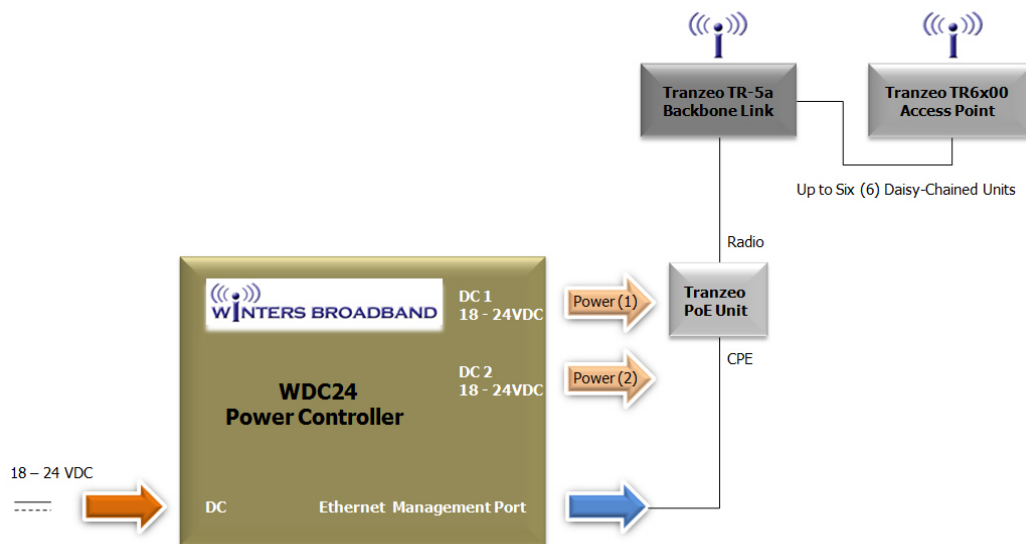

Figure 5: WDC24 Powered 2.4 GHz Access Point with 5.8 GHz Backbone Link no Switch

The WDC24 allows both the Access Point and Backbone Link wireless units to be monitored and corrective action to be taken upon failure of tests to either wireless unit.

4 POWER CONTROLLER MANAGEMENT

The WxC24 power controllers have an integrated web server which enables web based monitoring, management and configuration of the units. The WxC24 web management supports two privilege access levels:

- **System Monitor**
The "*monitor*" user only has access to the Monitoring user interface and cannot configure, or administer the WxC24 Power Controller in any way.
- **System Administration**
The "*admin*" user has full access to the Configuration, Administration, and Monitoring of the WxC24 Power Controller.

The following sections provide information on the various management features of the WxC24 Power Controllers.

4.1 Power Controller Configuration

The configuration of the power controllers is used to configure:

- DC power output control
- Automatic power cycling parameters
- Device monitoring parameters
- Email reporting
- Real time clock



Power Controller Configuration

Power Output: DC Output 1: DC Output 2: Power Off Time:

Power Cycle:
 DC Output 1: Weekday: Time: Time Off:
 DC Output 2: Weekday: Time: Time Off:

Monitoring:

Enabled	IP Address	S/W Output	Time Off
<input checked="" type="checkbox"/>	<input type="text" value="10.206.236.17"/>	<input type="text" value="1"/>	<input type="text" value="30 sec"/>
<input checked="" type="checkbox"/>	<input type="text" value="10.206.236.217"/>	<input type="text" value="2"/>	<input type="text" value="30 sec"/>
<input type="checkbox"/>	<input type="text" value="10.206.236.131"/>	<input type="text" value="2"/>	<input type="text" value="30 sec"/>
<input checked="" type="checkbox"/>	<input type="text" value="10.206.236.130"/>	<input type="text" value="2"/>	<input type="text" value="30 sec"/>
<input checked="" type="checkbox"/>	<input type="text" value="10.206.236.121"/>	<input type="text" value="2"/>	<input type="text" value="30 sec"/>
<input checked="" type="checkbox"/>	<input type="text" value="10.206.236.7"/>	<input type="text" value="2"/>	<input type="text" value="30 sec"/>

Test Sequence: Test Threshold: Test Interval:

Reporting: Event Reports

Real Time Clock: Date/Time (mm/dd/yy hh:mm:ss):

Figure 6: Power Controller Configuration UI

WxC24 Power Controllers Application Note

The WxC24 power controllers allow the two DC outputs to be controlled:

- **Manually**

The power outputs may be cycled (turned off) for a specified time by un-checking the either the DC Output 1 checkbox and/or the DC Output 2 checkbox. The power off time is selected from the Power Off Time drop down list. The selection is activated by selecting the "Submit" button.

If the Event Reports checkbox is enabled an email will be sent to the configured address providing details of the date, time and action taken.

- **Date and Time**

Operating conditions may make it desirable to reboot an Access Point or other device at regular intervals, for example to clear buffer usage. Since such action impacts the service being provided to customers the WxC24 power controllers allow for such actions to be scheduled when network usage is at a minimum, for example 3:00 am on a Sunday morning.

Each DC output may be configured to have its power cycled on a specific weekday at a specific time for a specified period. The Power Cycle parameters allow a different configuration for each DC Output.

If the Event Reports is enabled an email will be sent to the configured address providing details of the date, time and action taken.

- **On failure of specific device monitoring**

When an Access Point or backbone link locks up it requires that someone travel to the specific site to reset the device. This may not occur at the most convenient time of day or in the best of weather.

The WxC24 power controllers allow the monitoring of up to six IP addresses at configurable time intervals. At each time interval a test sequence is sent to each of the enabled IP addresses and the results are compared to the test threshold. If the results from the test sequence do not meet the test threshold the configured power cycle parameters for that IP address are implemented.

An example is for the first entry where IP address 10.206.236.17 is sent a sequence of 5 ICMP based tests. If the correct results are received from at least 4 (test threshold) of these tests no action is taken. If however the test threshold is not met and say only three correct results are received, then DC Output 1 will be power cycled off for 30 seconds.

Each IP address in the table can be enabled or disabled, allowing the monitoring to be configured and changed according to network operating conditions.

If the Event Reports checkbox is enabled an email will be sent to the configured address providing details of the date, time and action taken.

4.2 Power Controller Administration

The Administration web page allow configuration of the power controllers Ethernet parameters, name, location, passwords and email reporting parameters.



Power Controller Administration

Ethernet:	IP Address: <input type="text" value="10.206.1 67"/>	DNS Servers: <input type="text" value="198.6.1.142"/>
	Gateway: <input type="text" value="10.206.1.1"/>	<input type="text" value="198.6.1.146"/>
	Subnet Mask: <input type="text" value="255.255.254.0"/>	
Device:	Name: <input type="text" value="WAC24 Power Controller"/>	Location: <input type="text" value="Savanna AP"/>
Security:	User Name: <input type="text" value="monitor"/>	
	Password: <input type="text"/>	Re-enter Password: <input type="text"/>
	Administrator Name: <input type="text" value="admin"/>	
	Password: <input type="text"/>	Re-enter Password: <input type="text"/>
Email:	Send Address: <input type="text" value="monitor@your_email_server.com"/>	
	Device Address: <input type="text" value="wxc24@your_email_server.com"/>	
	Password: <input type="text"/>	Re-enter Password: <input type="text"/>
	SMTP Server Address: <input type="text" value="smtp.your_email_server.com"/>	

Figure 7: Power Controller Administration UI

In order for the power controller to be able to send email reports to a central monitoring location it must be configured with an email address, password, the SMTP server address and the address to which it must send its reports.

The email reports include the following parameters:

- Date and Time
- Device and Location
- IP Address
- Action taken

4.3 Power Controller Monitoring

The monitoring web page provides details as to current status of the power controller. Normally operating parameters are shown with a green indicator, failed or currently off parameters as shown with a red indicator and disabled parameters are shown with a grey indicator.

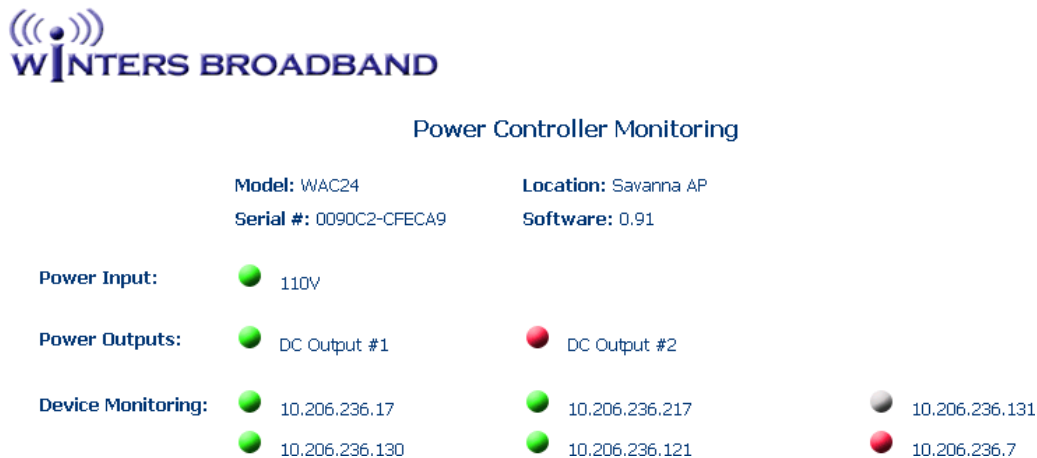

Figure 8: Power Controller Monitoring UI

In the screen capture shown above, the monitoring of the device with an IP address of 10.206.236.7 has failed the configured test sequence and is therefore shown with a red indicator. The configured test sequence specified that in the event of the test failing DC Output #2 should be power cycled (turned off) for a specified time, the red indicator for DC Output #2 indicating that this output is currently turned off.

The monitoring web page also provides information specific to the power controller which includes its model, location, serial number and current software release.

The monitoring web page is automatically refreshed every 30 seconds.

4.4 Monitor vs. Admin Privilege Summary

The following table provides a comparison of the Monitor and Admin privilege access.

Power Controller Management Functions	Admin Access	Monitor Access
Configuration	✓	✗
Administration	✓	✗
Monitoring	✓	✓

Table 1: Admin vs. Monitor Privilege Summary

WxC24 Power Controllers Application Note

5 SOFTWARE UPGRADES

The WxC24 power controllers have a Flash memory file system which allows the software to be upgraded to take advantage of new features. The upgrades can be done remotely without affecting operation of the attached powered or monitored devices. The power controllers store two versions of the software and will automatically reboot to the backup version should there be a failure in booting the primary version.

Software upgrade capability is only available to the System Administrator privilege level.

6 WxC24 POWER CONTROLLER SPECIFICATIONS

Specification	Product	
	WAC24	WDC24
AC Power Input	100 ~ 240V 47 ~ 63 Hz	
DC Power Input	18 ~ 24 VDC	
DC Outputs	Dual 24 VDC 1.5 A per output, 2.5A max. (60W)	Dual output Input voltage = Output voltage 1.5A per output
DC Output Control	Outputs may be switched based on rules or time of day	
Indicators (LEDs)	System Status DC Power Status (2)	
Monitoring	Power source status DC output status	
Management	Web based with two levels of authentication	
Alerts	Email	
Management Interface	Ethernet 10BaseT	
Monitored Devices	Up to six (6) Ethernet attached devices	
Operating Temperature	0 ⁰ C to 70 ⁰ C 32 ⁰ F to 158 ⁰ F	
Dimensions (w x h x d)	6.25" x 7.6" x 2"	4.8" x 5.3" x 1.5"
Warranty	1 year	

Table 2: WxC24 Power Controller Specifications

7 MORE INFORMATION

For additional information on the Winters Broadband WxC24 Power Controllers, please visit our web site at www.winters-broadband.com.

Winters Broadband LLC
P. O. Box 789
Winters, CA 95694
Tel: (530) 852-7990